



THA-UAC-BL / THA-UAC-BK アルミキャビネット取手

Cabinet Handle



特長

前面から取り付ける取手です。握りやすく信頼性・安定性に優れています。

用途

工作機械・治工具・特殊自動車・車輛通信機・オーディオ等

Characteristic

The handle which installs from the front side of panel. It has the shape and size for easy gripping. Excellent performances on reliability and stability.

Application

Machine tools / Jigs and tools / Special equipment vehicles / Telecommunication devices on vehicles / Audio devices, etc.

材質と処理 Material & Finish

型番 Model No.	材質 Material	処理 Finish
THA-UAC-BL	AL	バレル研磨 Barrel Polishing
THA-UAC-BK		塗装(黒色) Paint (Black)

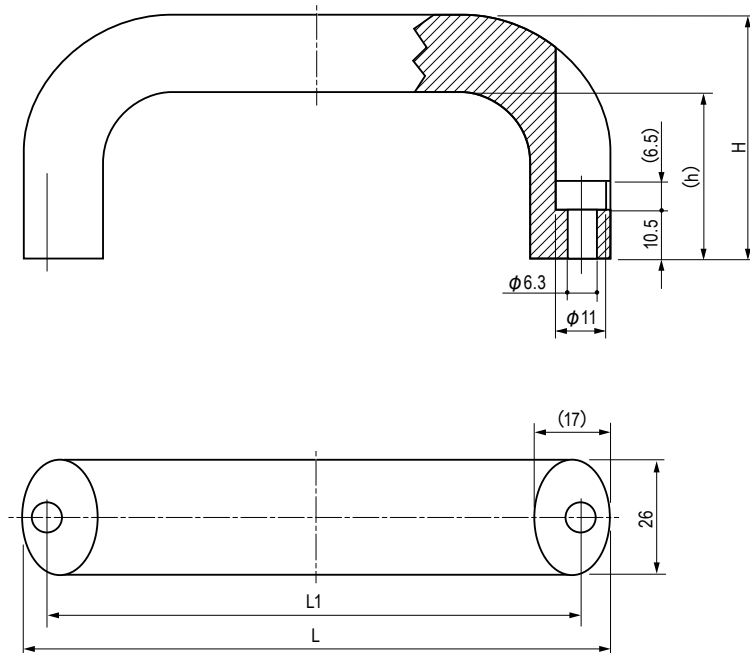

寸法・仕様表 Size List & Specification THA-UAC-BL (バレル研磨 Barrel Polishing)

型番 Model No.	L	L1	H	h	垂直許容荷重 kN (kgf) Allowable Vertical Load kN (kgf)	自重 (g) Net Weight (g)
THA-UAC-26x116-BL	130	116	55	38	1.57 (160)	157
THA-UAC-26x132-BL	146	132			1.08 (110)	178
THA-UAC-26x164-BL	178	164	57	40	0.78 (80)	209
THA-UAC-26x196-BL	210	196			0.49 (50)	242

寸法・仕様表 Size List & Specification THA-UAC-BK (塗装(黒色) Flat Black)

型番 Model No.	L	L1	H	h	垂直許容荷重 kN (kgf) Allowable Vertical Load kN (kgf)	自重 (g) Net Weight (g)
THA-UAC-26x116-BK	130	116	55	38	1.57 (160)	157
THA-UAC-26x132-BK	146	132			1.08 (110)	178
THA-UAC-26x164-BK	178	164	57	40	0.78 (80)	209
THA-UAC-26x196-BK	210	196			0.49 (50)	242

特注品のご相談承ります Please contact us for custom-made.