



# TM-LP-3 / TM-LP-6 TM-LP-12 / TM-LP-18 レベルパット

Level Adjuster



**特長**

接地面の傾斜や機器の取付部の曲がり等にも対応し、水平に固定することが可能です。また、ハンドル操作で簡単にレベル調整が行えます。

**用途**

工作機器・電算機・測定機・制御盤等

**Characteristic**

Corresponding to inclination of tread or bending of fixing part of device, it is possible to fix horizontally. Level adjusting can be easily done by operating the handle.

**Application**

Machine tools / Computers / Measuring instruments / Control boards, etc.

**部品表 Parts List**

部番 No.	部品名 Part Name	材質 Material		処理 Finish		数 Quantity
		TM-LP-3・6	TM-LP-12・18	TM-LP-3・6	TM-LP-12・18	
1	取付ボルト Bolt					1
2	六角ナット Hexagon Nut	SS400	SS400	3 価クロメート Trivalent Chromate Treatment	3 価クロメート Trivalent Chromate Treatment	1
3	平座金 Flat Washer	S	S			1
4	ユニバーサルワッシャ Washer	SS400	FCD450	塗装(銀色) Paint (Silver)	塗装(銀色) Paint (Silver)	1
5	ジャッキ Jack	FCD450				1
6	フレーム Frame			塗装(銀色) Paint (Silver)	塗装(銀色) Paint (Silver)	1
7	フット Foot	NBR	NBR	黒色 Black	黒色 Black	1

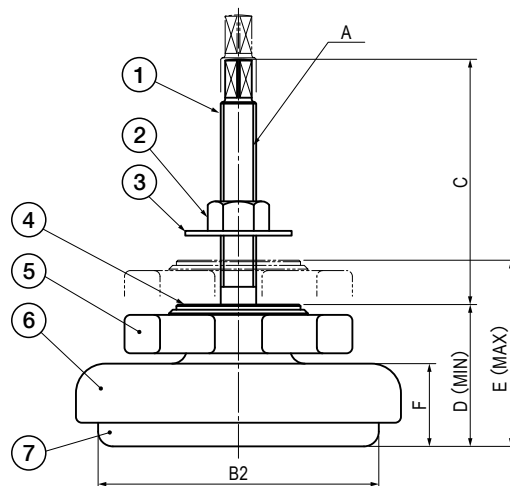
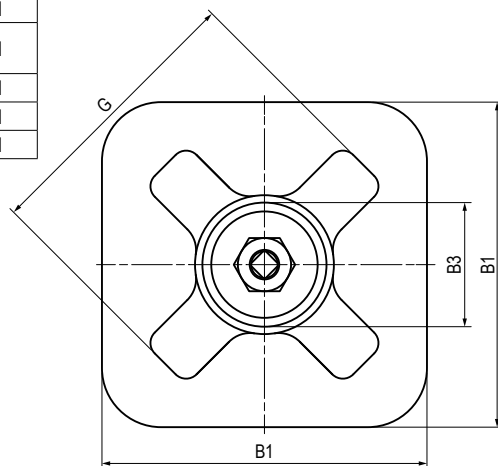

**寸法・仕様表 Size List & Specification**

型番 Model No.	A	B1	B2	B3	C	D	E	F	G	垂直圧縮許容荷重 kN (kgf) Allowable Vertical Compressive Load kN (kgf)	自重 (g) Net Weight (g)
TM-LP-3	M12 × 1.75	110	95	φ42	80	49	64	28	95	2.94 (300)	1700
TM-LP-6	M16 × 2	130	115	φ60	84	51	66	31	120	5.89 (600)	2400
TM-LP-12	M18 × 2.5	180	166	φ80	90	68	90	34	180	11.8 (1200)	6000
TM-LP-18	M20 × 2.5	220	206	φ95	90	75	100	38	220	17.7 (1800)	9000

特注品のご相談承ります Please contact us for custom-made.