

TM-16 カードホルダー

Card Holder



特長

各種銘板・分類カード等を機器筐体等に取付ける為のホルダーです。

用途

工作機器・OA 機器・家具・筐体ケース・通箱等

Characteristic

A holder to put a faceplate or classification card on a device chassis.

Application

Machine tools / Office automation appliances / Furniture / Box cases / Delivery boxes, etc.

材質と処理 Material & Finish

材質 Material	処理 Finish
C2801	Ni

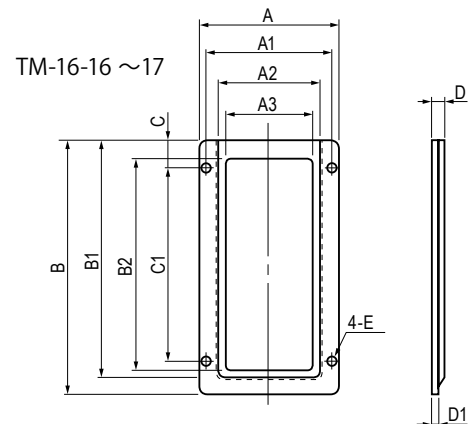
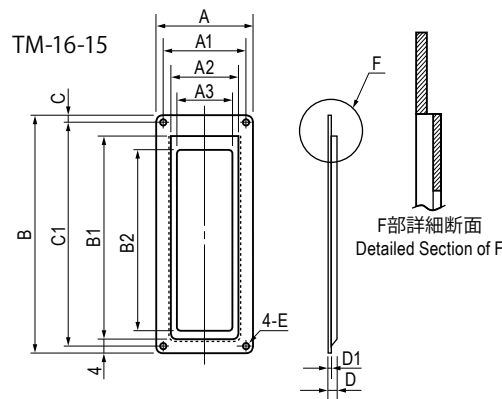
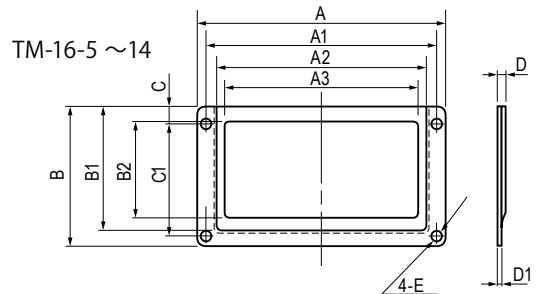
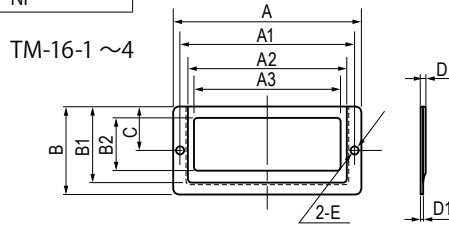

寸法・仕様表 Size List & Specification

型番 Model No.	A	A1	A2	A3	B	B1	B2	C	C1	D	D1	E
TM-16-1	30	25.5	20.5	17	11	9	6.5	5	—	1.5	t0.5	φ1.6
TM-16-2	35	32.5	27	22.5	15	12.5	9	7.5				
TM-16-3	40	35.5	30	27.5	20	16.2	11	10				
TM-16-4	46	42.5	38	35	23	20	15	11.5				
TM-16-5	50	45	40.5	36	25	20.5	20	3.5	17	1.7	t0.5	φ1.9
TM-16-6	55	51	45	40	30	26		23				
TM-16-7	60	56	50	46	33	29	23.5	4.5	26	1.5	t0.5	φ1.9
TM-16-8	65	60	55	50	35	30.5	25	3.5	28.5			
TM-16-9	75	71.5	64.5	55	40	37	30	5	33	1.7	t0.8	φ2.2
TM-16-10	80	74.5	69	60	45	39.5	33		34			
TM-16-11	85	81	71	65	50	44	35	5.5	35.5	2	t0.8	φ1.2
TM-16-12	95	90	84	73	49	42	32	6	32.5			
TM-16-13	118	111.5	105	95	66	58.5	49	6.5	48	1.6	t0.5	φ1.6
TM-16-14	147	139.5	131	118	91	80	66	7.5	67.5			
TM-16-15	25	22	18.5	15	50	41	35	2	47	1.5	t0.5	φ1.6
TM-16-16	35	32	27	23	55	51	45	6	43			
TM-16-17	45	40	34	30	70	63.5	55	5	59	1.6	t0.5	φ1.7

Level Adjusters & Positioning Level Adjusters
マシンツール・OA機器・家具
レベル調整器

Rubber Feet
ゴム足・各種足

Grommets & Others
グロメット・その他部品

Sealing Rubber Gaskets
防塵ゴム・パッキン

Magnetic Belts & Sheets
スリットマグネットベルト

Slide Rails & Rollers
スリットレール・ローラー

Chains & Wires
鎖・ワイヤー・金具等

Others
その他